



FILTER PRESS TECHNOLOGY

HIGH PERFORMANCE DEWATERING APPLICATIONS FOR MINING

INDUSTRY LEADING TECHNOLOGY

DEDICATED SOLUTIONS FOR THE MINING INDUSTRY

Evoqua delivers the highest quality and most reliable filter press dewatering solutions to the mining industry. Our unrivaled experience and portfolio of products deliver the highest performance and return on investment — improving your operating efficiency and enhancing your competitive advantage.

Our presses are known world wide for their precision engineering, rugged construction and reliable operation. Backed by a dedicated staff of dewatering professionals, our global technical support and service capabilities will make sure that you achieve the longest life and lowest cost of operation for your press.

With thousands of installations around the world, you can trust Evoqua to take care of all your dewatering needs.

BUILT TO THE HIGHEST STANDARDS

Designed and manufactured under the strictest ISO 9001:2008 quality management system, filter presses from Evoqua provide solutions specifically for your unique mining application. Whether you require higher solids throughput for mineral concentrates, tailings, or a high rate filtration application, we have a high performance filter press in our portfolio for you.

IMPROVED UPTIME, EFFICIENCY AND COSTS

- The driest cake — minimizes handling and processing costs
- The clearest liquid effluent — suitable for reuse, improves water conservation
- Reliable performance and very high uptime — reduces operating costs
- Durable robust design and construction — minimizes maintenance costs

FLEXIBLE PRODUCTS FOR EVERY MINING APPLICATION

Evoqua provides efficient and cost effective dewatering solutions for a full range of mining applications, with unique features to suit your individual needs.

Our MC Press® filter press is a high speed, fully automated solution, ideally suited for applications that dewater quickly and require high throughput. Typical applications include:

- Mineral concentrates
- Tailings
- Other high throughput, rapid dewatering applications

The J-Press® filter press is a traditional style press available in a wide range of sizes and features for applications such as:

- Merrill Crowe Process
- Electro winning carbon fines
- Slimes filtration
- Crud filtration
- Acid mine drainage treatment systems
- Acidic and alkali suspensions

MC PRESS® FILTER PRESS

SOLID PERFORMANCE

The MC Press® filter press is one of the most versatile dewatering devices for use in high capacity, high throughput, high solids dewatering applications common to mineral concentrate processing. With durable, reliable, heavy-duty construction and innovative design features, the MC Press filter press maximizes uptime and reduces costly, unscheduled maintenance that can interfere with production. These flexible, large capacity presses include the ability to increase capacity to meet future throughput requirements without modification to the equipment footprint.

LOWER OPERATING COSTS PER TON

The simplified operation of the MC Press filter press incorporates a minimum of moving parts, offering a long and dependable life with minimal preventative maintenance requirements. The simple and fully automated operation also achieves fast cycle times for higher through-put rates to keep pace with your production demands, reducing the size and cost of the presses. In fact, the MC Press filter press has demonstrated the lowest operating costs per ton among similar presses in the mining industry.

IMPROVED DOWNSTREAM PROCESSING EFFICIENCY

The unique ability of the MC Press filter press to provide a reliable high solids cake is second to none. These presses consistently produce cakes with moisture content as low as 6-8 percent for most mineral concentrate applications. High discharge consistency, coupled with the lowest cake moisture content means downstream processing can run with optimum performance.

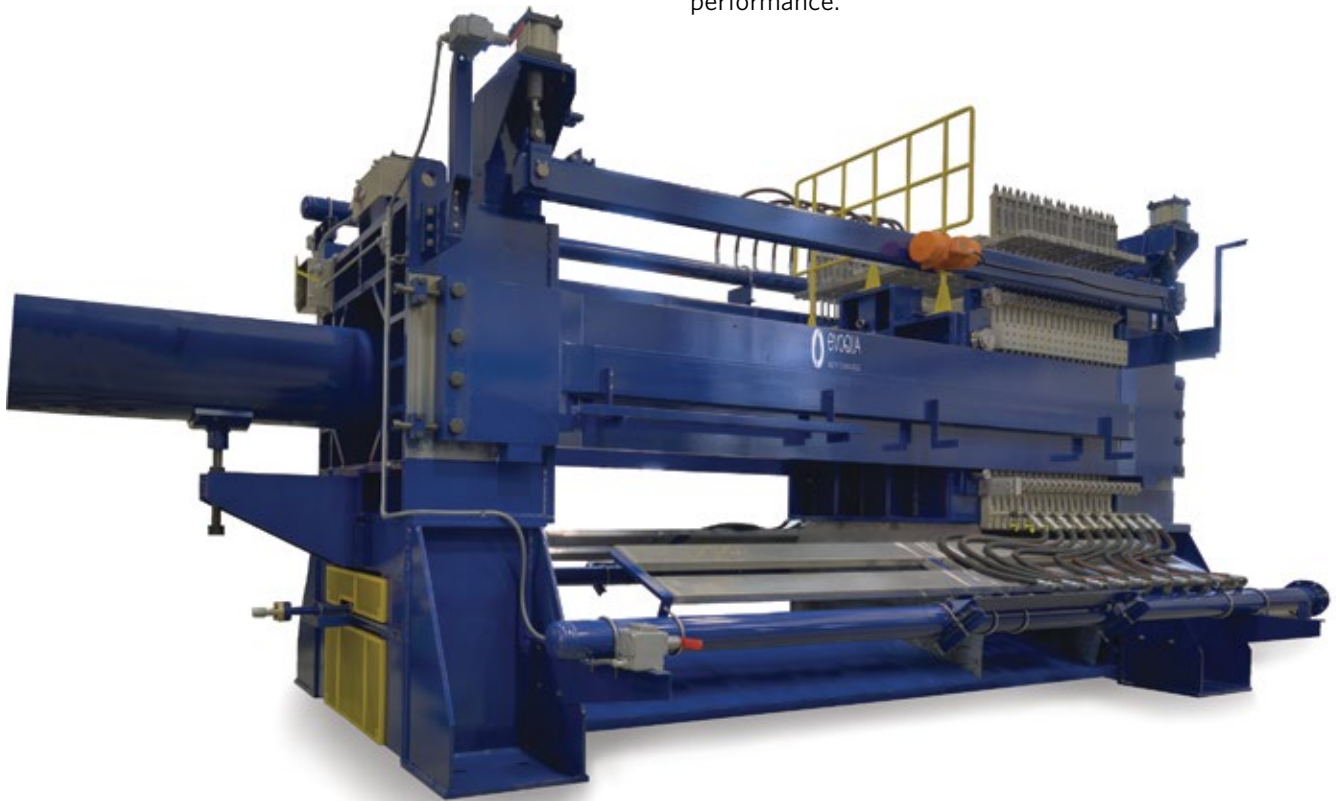

1.5 m x 1.5 m H model

MAXIMUM PROCESS EFFICIENCY

HIGHER THROUGHPUT FROM FASTER, AUTOMATED CYCLES

With a mineral concentrate press cycle of 8-12 minutes depending on the model and number of plates, the MC Press® filter press provides an exceptionally high throughput rate. Feed times typically range from 1.5-2.5 minutes, with filter plates linked together accordion-style for rapid cake discharge. These efficiencies allow the press to complete as many as 150 cycles per day without interruption. The MC Press filter press also benefits from a complete automation and instrumentation package, eliminating the need for an operator. A feed flow meter and pressure transmitter indicate press fill completion, and load cells determine the solids production rate while controlling moisture during cake air blow.

BACKUP CAKE DISCHARGE MECHANISM

The MC Press filter press employs a dual system to ensure discharge of all dewatered filter cakes. Filter cloths suspended by spring-supported bars are pulled down by the weight of the filter cake, stopping suddenly at the end of their travel, and shearing the cake from the cloths. The springs then return the bars to their normal raised position. Should the cakes fail to discharge, the cloth support bar remains in the lowered position. After a photo-eye verification of the discrepancy, a vibration bar engages it to ensure complete filter cake discharge. If the cloth support bar continues to remain in the lowered position, the press cycle stops and an alarm sounds, ensuring the press does not operate with cakes remaining in their filter chambers. As a critical step to ensure maximum cloth life and proper press sealing, a cloth wash system removes all remaining solids after each cake discharge cycle.

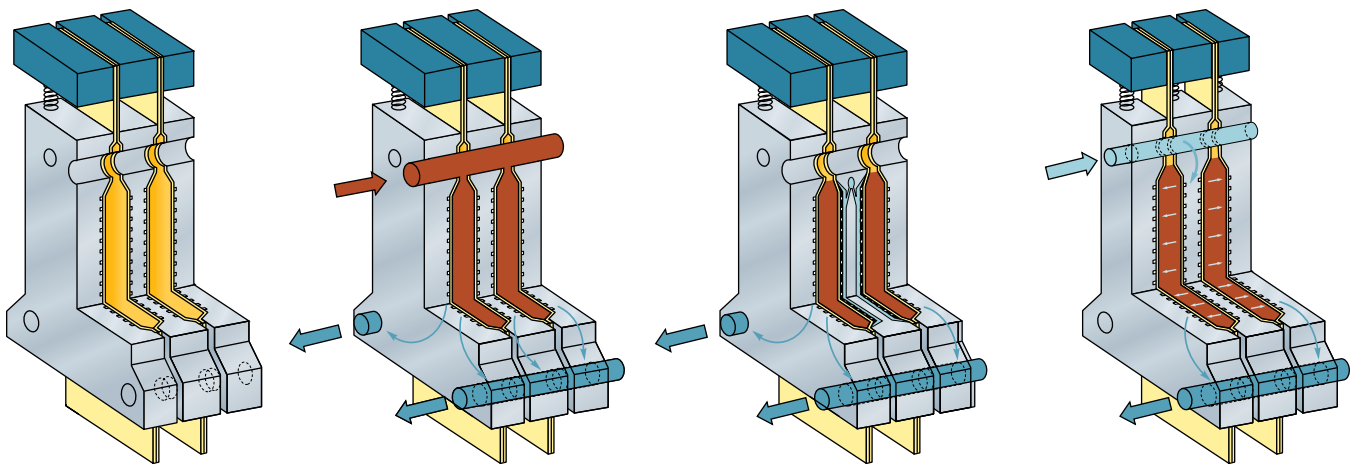

STEP 1. PRESS CLOSE AND CLAMP

Filter plates are pushed together to form a series of filter chambers. After initial closing, a high pressure hydraulic cylinder clamps the plates securely together to prevent leaking during the dewatering and air blowing cycles.

STEP 2. SLURRY FEED AND DEWATERING

After the plates are clamped together, an internal feed manifold is formed by the plate cores. Slurry is pumped through the feed core and is directed between the two filter cloths that form each chamber. Flow continues until the chambers are full.

STEP 3. MEMBRANE SQUEEZE (OPTIONAL)

When filter cakes are compressible or have the potential to crack, specially designed membrane plates are used to mechanically compress the cakes.

STEP 4. CAKE AIR BLOW

Compressed air is fed into one side of each chamber, displacing cake moisture in the filter cake. The air and displaced liquid exits through the filtrate ports ensuring a consistently dry cake.



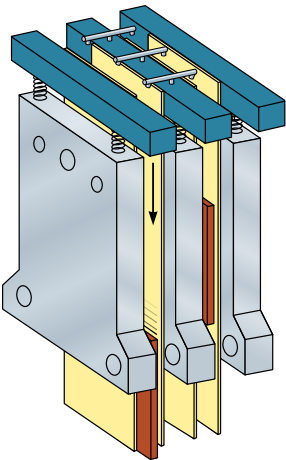

STEP 5. PRESS OPEN AND CAKE DISCHARGE
 Filter cloths are suspended from spring supported bars. As the press opens, the filter plates are separated in rapid succession. As each chamber opens, the weight of the filter cake pulls the filter cloth down. At the end of the spring travel, the sudden stop shears the cake from the cloths, allowing cakes to rapidly and completely discharge.

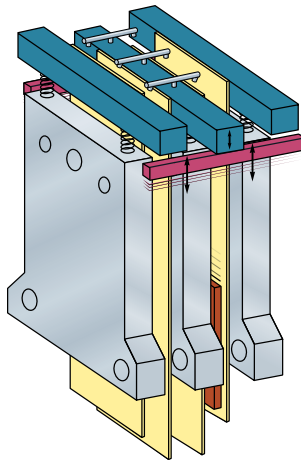

STEP 6. BACKUP DISCHARGE MECHANISM
 If abnormalities in the operating process arise which result in incomplete cake release, a backup cake discharge assist mechanism is automatically activated. Rails are lifted into contact with the lowered cloth support assembly and its attached cake. A vibration system is then activated to dislodge the sticking cake, ensuring complete cake discharge without manual intervention.

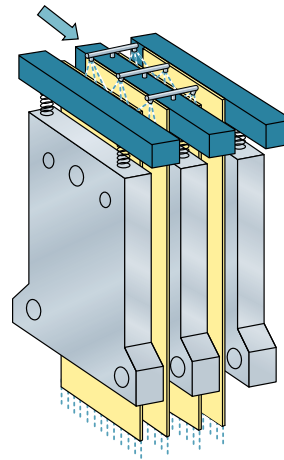

STEP 7. CLOTH WASH
 With the diverter doors closed and the press open, stationary showers affixed to the top of the filter plates are actuated, washing all of the exposed filter cloths. The wash water flows down the entire face of the cloths for a complete and efficient cleaning. This extends cloth life and ensures positive press sealing.

THREE FRAME DESIGNS TO MATCH YOUR CAPACITY REQUIREMENTS

The MC Press® filter press is available in three unique frame designs, with plate sizes of 1.5 m x 1.5 m and 1.5 m x 2.0 m. All are available in a range of cake thickness and operating pressures to meet a wide variety of applications and production requirements. Each press can be further customized with either recessed chamber or membrane squeeze plates depending on your individual needs.

H MODEL

The H model incorporates a single, long stroke, hydraulic cylinder to close and clamp the plate stack and move the plates for cake discharge. Plates are linked together, allowing the filter cakes to discharge simultaneously as the press is pulled open by the hydraulic cylinder.

The H model is available with up to 50 filter chambers for a throughput capacity of up to 65 tonnes/hour on a typical mineral concentrate.

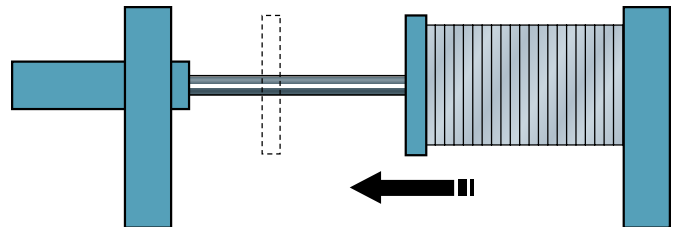

S MODEL

The S model incorporates four short stroke hydraulic cylinders to clamp the plate stack and a plate traveler mechanism to retract the follower. Plates are moved by a mechanical chain drive system and are linked together, allowing the filter cakes to discharge as the press is pulled open by the drive assembly.

The S model is available with up to 64 filter chambers for a throughput capacity of up to 90 tonnes/hour on a typical mineral concentrate.

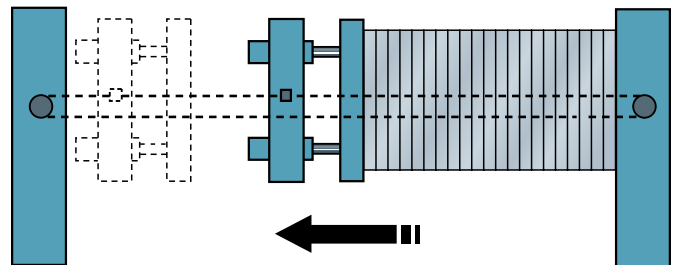

D MODEL

Ideal for larger operations, the D model incorporates many of the same features as the S model, with four short stroke hydraulic cylinders, a mechanical drive system for cake discharge, and linked plates. Both ends of the D model press move simultaneously, further increasing efficiency by speeding cake discharge.

The D model is available with up to 130 filter chambers for a throughput capacity of up to 170 tonnes/hour on a typical mineral concentrate.

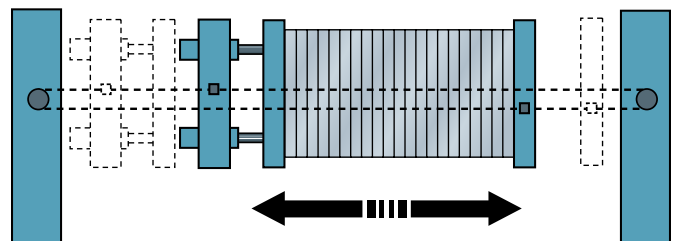

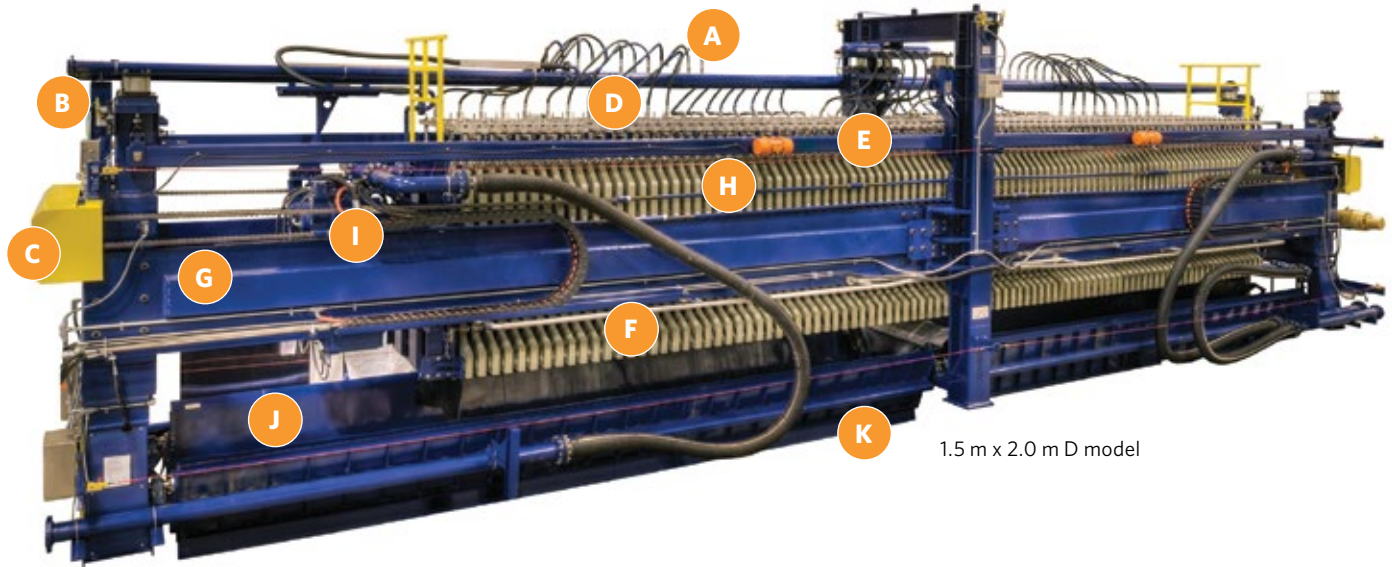

1.5 m x 2.0 m D model

INNOVATIVE FEATURES WITH MULTIPLE ADVANTAGES

A. CLOTH WASH SYSTEM

Feature: All cloths are washed after every cake discharge cycle.

Advantage: Extends cloth life and improves press operation by cleaning the sealing surfaces between plates preventing production losses.

B. CAKE DISCHARGE MONITORING SYSTEM

Feature: Photoelectric beam checks to determine that all cloths are in raised position when press is fully open.

Advantage: Insures that all cakes have discharged from the press before proceeding with the next cycle.

C. PLATE TRAVEL ASSEMBLY (S & D MODELS)

Feature: The press is opened and closed by a simple mechanical drive system that is easy to understand and maintain.

Advantage: Reduced maintenance costs. No special tools or specialized maintenance training required.

D. SPRING SUPPORTED CLOTH BARS

Feature: Cloths move down as cakes are discharged. Cakes shear from cloths when cloth support bars reach the end of their travel.

Advantage: Proven to be the most reliable method of filter cake discharge.

E. VIBRATION BARS

Feature: Act as a backup to the primary cake discharge system. Activated when cake discharge monitoring system detects that one or more cakes have not discharged.

Advantage: Assists with filter cake discharge if process conditions change and cakes become sticky.

F. LINKED FILTER PLATES

Feature: The dewatered filter cakes are quickly discharged as the press opens.

Advantage: Shorter cycle times and greater throughput.

G. PRESS FRAME

Feature: Can be provided with capacity for additional filter plates.

Advantage: Press can be easily upgraded at minimal cost for greater throughput in the future.

H. FILTER PLATES

Feature: Lightweight polypropylene with excellent corrosion resistance. Replaceable wear components in critical areas.

Advantage: Extended plate life and lower operating costs.

I. HYDRAULIC CLAMPING CYLINDERS

Feature: Maintains proper clamping force during the press cycle. Cylinders are rugged and easy to maintain.

Advantage: Maintenance costs are minimized.

J. DIVERTER DOORS

Feature: Close to prevent wash water from entering the cake transport system. Open to allow discharge of cake. Rugged, heavy duty design, automatic operation.

Advantage: Prevents cloth wash water from re-wetting filter cakes after discharge. Minimal maintenance, no operator requirement.

K. WASH TROUGHS

Feature: Channel wash water from the diverter doors to a drain. V" bottom with flush nozzles located at each end to prevent solids buildup.

Advantage: Reduces maintenance requirements to clean out clogged troughs.

J-PRESS® FILTER PRESS

THE CUSTOMIZABLE AND COST EFFECTIVE SOLUTION

Rugged construction. Precision engineering. Simple operation. J-Press® filter presses are known world wide for reliable performance at the lowest life cycle costs and consistently producing high solids filter cakes and high clarity filtrate in the most demanding applications.

The result of decades of diverse application, operating and research experience, the J-Press filter press provides an excellent alternative to the MC Press® filter press for many low- to medium-throughput mineral concentrate and general dewatering applications, or smaller or specialized mining industry applications such as electro winning residuals, crud filtration and the Merrill Crowe Process.

The J-Press filter press line by Evoqua is unrivaled in the industry for quality and reliability. Evoqua offers J-Press technology in a range of capacities, from as small as 11 liters to capacities as large as 17 m³. They are available in sidebar and overhead styles which can be configured in manual, semi-automatic or fully automated versions to meet your exact requirements. Their inherent flexibility ensures you can find the best possible performance for your specific application.

MERRILL CROWE PROCESS

With over 100 installations worldwide, the J-Press® filter press is the preferred choice for Merrill Crowe filtration processes. Since our first Merrill Crowe installation in 1988, Evoqua has been building presses specifically designed for the precise requirements of this critical application.

In order to provide the optimal filter press to meet your specific needs, we offer multiple choices for customization, including:

- Systems ranging from completely manual to fully automated
- Flexible press and plate sizes to suit any installation flow requirement
- Your choice of plate styles
 - Plate and frame for use with filtration papers
 - Recessed chamber for use with precoat cloths
- A full range of ancillary support equipment, including precoat systems, feed pumps conveyors and control systems

J-PRESS® FILTER PRESS

Feed solids	Typically 0.5 to 3%
Capacity	Up to 17 m ³ /cycle
Applications	<ul style="list-style-type: none">• Small volume mineral concentrate• Electro winning carbon fines• Slimes filtration• Crud filtration• Merrill Crowe Process• Acid mine drainage• Acidic and alkali suspensions



INCREASED VERSATILITY FOR YOUR FILTER PRESS SYSTEM

Evoqua offers a broad selection of filter plates and cloths which add to the versatility of the MC Press® and the J-Press® filter presses.

FILTER PLATES

- For most applications, filtration plates made of polypropylene are the best choice as they have high chemical resistance properties, are lightweight yet durable and have excellent wear characteristics.
- For applications with compressible solids, plates fitted with a diaphragm squeeze system are available.
- For highly abrasive applications such as mineral concentrates, Evoqua has developed innovative filter plate features to ensure long life and reduced maintenance.

FILTER CLOTHS

Evoqua has the expertise to select the best fit for your application and desired results. Our filter cloths are available in a wide variety of weave patterns, weights, materials and porosities.



1.5 m x 2.0 m MC Press® membrane plates provide high capacity filtration

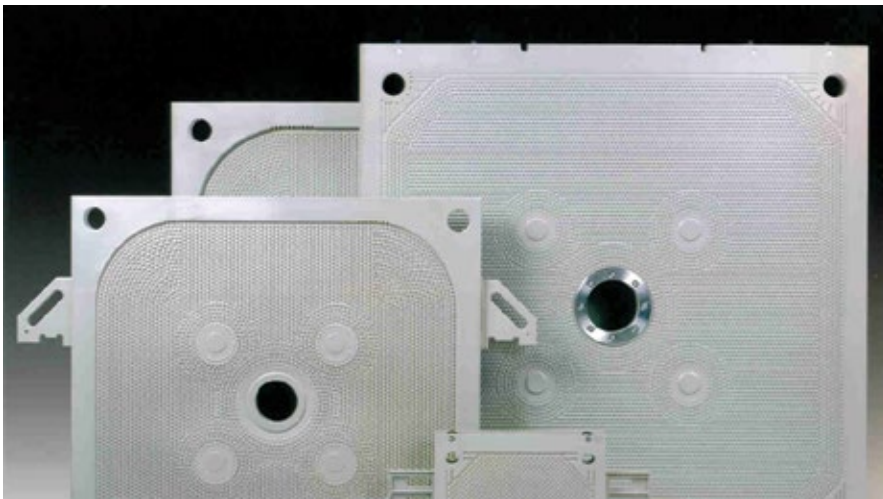

J-Press® filter plates



Evoqua Holland, Michigan, USA facility

EXCELLENCE AT EVERY STEP OF THE PROCESS

WORLD CLASS MANUFACTURING CAPABILITIES

The J-Press® and MC Press® filter presses are manufactured at our Evoqua Holland, Michigan, USA facility, a 165,000 sq. ft. (15,329 m²) manufacturing and engineering complex. Here, under one roof, each press is engineered and built using state-of-art CAD and CAM technologies to assure on-time delivery of even the largest project.

WORLD CLASS COMMITMENT

Evoqua is committed to being a dynamic global competitor — removing inefficiencies from the manufacturing process and empowering our organization to deliver greater value at a lower cost. Through our Continuous Improvement Program, we honor that commitment every day, at each of our global facilities and through every customer interaction.



AROUND-THE-CLOCK SERVICE, ACROSS THE GLOBE

Evoqua expertise is always ready to help you get the most out of your investment in our high-quality filter presses. Our applications are backed by the most experienced staff of engineers, technicians and customer service representatives in the industry. We provide end-to-end services from preliminary research and feasibility testing, to preventative maintenance, parts and refurbishment, all to ensure your press provides years of optimum performance.

CUSTOM SOLUTIONS

Using your actual materials in our laboratory, we identify critical design criteria to deliver the most cost-effective filter press for your exact application. Portable pilot units are available for on-site testing so you can experience the press in action.

PREVENTATIVE MAINTENANCE

Customized contracts are developed specifically for you which lowers your maintenance cost ensuring years of worry-free operation. Our factory trained maintenance teams are strategically deployed to be there when you need them.

TECHNICAL SUPPORT AND SPARE PARTS

Our expert technical consultants provide quick and reliable answers to your questions to help you diagnose and remedy situations you may encounter. We also provide same-day shipment on many parts to keep your press in operation.

REFURBISHMENT SERVICES

We extend the life of your equipment and reduce unnecessary expenditures by partial or complete refurbishing and rehabilitation to a warranted, like-new condition. This can be done on-site or in our factory.



