

PACIFIC OZONE™ PGS SERIES PACKAGED OZONE GENERATOR SYSTEM



COMPACT AND COMPLETE PACKAGED SYSTEMS

PGS Series Ozone Disinfection Systems are compact products designed for quick and seamless integration into your water or disinfection system and process. The PGS Series offers efficient production and delivery of 18-70g/h ozone with the latest performance and safety features. Designed for sanitary industrial applications, the PGS Series are easy to integrate and automate with pharmaceutical, beverage & food, personal care, and other industrial processes. The PGS Series will arrive at the site fully commissioned and qualification ready for quick setup to perform disinfection and sanitization tasks with tanks or in-line processes. High performance and simplicity for the most demanding ozone disinfection applications.

With the Pacific Ozone™ Packaged generator systems, all you need is air, water, and electricity to increase the efficiency and safety of your process.

COMMISSIONING AND QUALIFICATION READY

Designed with proven performance characteristics using advanced instrumentation and software to manage ozone production, mass transfer efficiency, precision control, and monitoring and safety to exceed the most rigorous user requirements and specifications.

ADVANTAGES OF PACKAGED OZONE DISINFECTION SYSTEMS

Pacific Ozone™ Packaged Ozone Disinfection Systems, exclusively from Evoqua, are designed to control the variables inherent in oxidation processes to deliver maximum efficiency and ease of system operation and validation. Packaged Ozone Disinfection Systems are designed, tested, and qualified for the most demanding industrial, mission-critical processes. All critical performance characteristics in the ozone process are measured with advanced software and feedback mechanisms for ease of operation and reliability. The advanced and fully integrated monitoring and verification of all instrumentation and process parameters in real-time provides immediate information on the process to maintain the tightest operating requirements specifications.

CONFIGURATIONS

There are two core configuration designs to the PGS series, based on the ozone injection methodology: Passive or Active injection. The Passive injection configuration leverages an integrated off-gas separator and destruct for unique treatment within the integrated mixing vessel. This process leverages the process flow of the treated water. The Active injection configuration leverages your storage tank and recirculates water in for treatment by chasing a set point in the tank. This is managed through the smart logic of the HMI and the integrated Ambient Ozone Detectors (AO₃) and Dissolved Ozone Analyzer (DO₃). An optional second configuration of the Active Injection design is to add an additional DO₃ analyzer.

FEATURES

- Corrosion Resistant Stainless Steel
- Easy-to-Use Software and 10" HMI Touch Screen
- Air-Cooled FPT Titanium Reactor Cells
- No Cooling Water is Required
- Precision Linear Ozone Control by Powertron
- On-Board Concentrated Oxygen
- Stainless Steel Construction
- Ethernet/IP Network Capable

BENEFITS

- Energy Efficient - Low Operating Costs Paired with On-Demand Based Ozone Generation
- Low Capital Investment for Capacity
- Simple Install and Integration
- System Commission & Qualification Ready
- Automated Start, Stop & Purge Sequencing
- Visual Ozone Indication
- Ideal for Upgrading Existing Systems

MARKETS

- Aquaculture
- Food & Beverage
- Pharmaceuticals



Sanitary design, back-flow prevention and process instrumentation are standard on all PGS systems.

PEACE OF MIND IN PERFORMANCE

The PGS Series offers proven and reliable ozone outputs. The performance can easily be verified, when required, delivering qualified and verifiable performance. With real-time monitoring and quality design, the units require less maintenance and provide more process uptime to keep your production

efficiency high. All PGS Series systems are engineered to meet all of the ozone process requirements found in the most demanding applications. They are simple to operate, easy to move or store, will provide years of trouble-free operation, and therefore are the perfect solution for today and tomorrow.

THE POWERTRON DIFFERENCE

Powertron is our latest innovative technology aimed at helping you maximize your operational efficiency. Now integrated into our complete product lineup, this novel power supply design provides a new method to control power for precision O₃ output that uses less energy. With 100% linear turndown capability, this advanced technology provides stabler and quieter performance with its enhanced, robust design. The design offers revolutionary and precise control of the power in the cell to produce the corona, so energy does not become wasted heat. The design allows for unique monitoring of electrical parameters to deliver efficient energy usage reliably while improving performance and reducing maintenance needs.

SIMPLE. PROVEN. OZONE TECHNOLOGY.

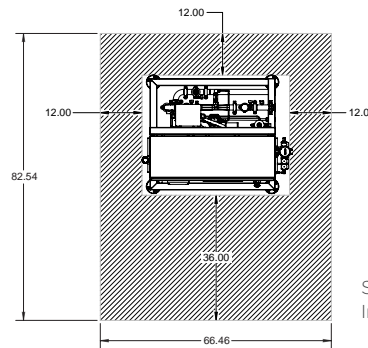
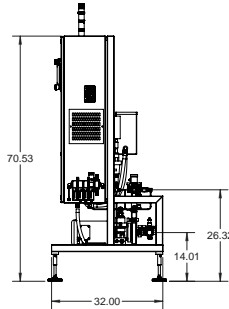
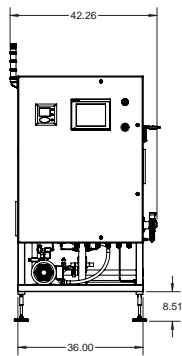

Shown is the PGS Active Injection view.

TECHNICAL SPECIFICATIONS*

	Ozone Production (g/h)	Normal Flow (SCFH)	Compressed Air (SCFM)	Reactor Cell Operating Pressure (psi)	Power Consumption (Watts)	Dimensions (WxDxH)
Active Injection	18	10	5	6-9	7.2	36 x 32 x 71
	36	20	5	6-9	7.2	36 x 32 x 71
	54	30	10	6-9	7.2	36 x 32 x 71
	70	40	10	6-9	7.2	36 x 32 x 71
Passive Injection	36	20	5	6-9	7.2	32 x 32 x 71

*Nominal, under standard conditions.



AQUAANALYTIC LLC



Business Center 1, M Floor,
The Meydan Hotel, Nad AlSheba,
Dubai, U.A.E.

+31 715 69 01 51

<https://aquaanalytic.ae>
info@aquaanalytic.ae