

ULTRA CLEAR® RO DI ULTRA PURE WATER SYSTEM

HIGH QUALITY - LOW PRICE

The Ultra Clear® RO DI Series delivers permeate water with a salt reduction of approximately 98 %. The Ultra Clear RO DI Series system will polish the RO permeate to a quality of $< 0.1 \mu\text{S}/\text{cm}$. At a 98 % rejection rate, the RO permeate water that originated from a $400 \mu\text{S}/\text{cm}$ feed water source would still have a conductivity of about $8 \mu\text{S}/\text{cm}$. The Ultra Clear RO DI Series System polishes this water to $< 0.1 \mu\text{S}/\text{cm}$. The deionization module is delivered with the Ultra Clear RO DI Series System. These modules are directional and will require replacing at a frequency dependent on feed water quality and water consumption. A changing interval of about 3 months is typical. The DI modules are a lower cost alternative to electro-deionization systems such as our Ultra Clear RO EDI Systems. However, a regular change of the modules are necessary.

An Ultra Clear RO system with DI module delivers water with a quality that fulfills the needs of most laboratory requirements. All systems display inlet and product water quality. The salt reduction rate will be shown in percentage.

Storage Tanks are available with 30, 60 and 80 liter. There are storage tanks up to 3.000 liter available as needed.

Benefits

- Simple change of modules due to quick-fit coupler
- Service/maintenance report
- High capacity of DI modules
- Scope of supply includes consumables
- Made in Germany

Typical Applications

- Feed for laboratory ultrapure water systems
- General chemistry
- Laboratory washing machines including final rinse
- Feed for autoclaves and climate chambers
- Buffer preparation
- Photometry
- Spectrophotometry
- Media preparation



SPECIFICATIONS

System Performance		Ultra Clear RO DI 20	Ultra Clear RO DI 30
Production rate	l/h	20	30
Permeate conductivity	µS/cm	< 0.1	< 0.1
Rejection rate up to	%	96	96
Rejection rate for bacteria	%	99	99
Rejection rate for particles	%	99	99
Feed Water Specifications			
Pressure	bar	2 - 6	2 - 6
Conductivity	µS/cm	< 2000**	< 2000**
CO ₂	mg/l	< 15**	< 15**
Silt density index	SDI	< 12**	< 12**
Free Chlorine	mg/l	< 0.1	< 0.1
Total iron	mg/l	< 0.1	< 0.1
Shipping weight	kg	33	34
Power consumption	kW/h	0.2	0.2
Power supply	v/Hz	240/50 - 60*	240/50 - 60*
Dimension (H x W x D)	mm	530 x 340 x 420	530 x 340 x 420
Item code		W3T441747	W3T441748

* 115V upon request; ** with a pre-filter

CONSUMABLES

Item Number	Description	Change Frequency*
W3T197613	Pre-treatment module AMB	3 - 6 months
W3T197618	Deionization module VMD	3 months
W3T197620	RO module 20 l/h	2 - 3 years
W3T439875	RO module 15 l/h **	2 - 3 years
W3T199197	CO ₂ Trap CT1, replacement 30, 60, 80 l tank	12 months
W2T558519	UV Kit 30, 60, 80 l tank	12 months

* Change intervals possibly shorter, depending on feed water and consumption.

** Amount of modules depends on system size.

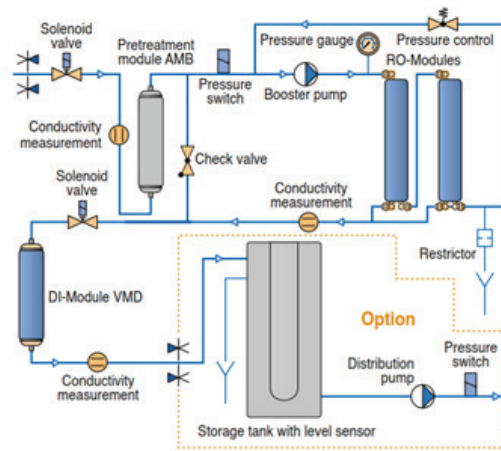

ACCESSORIES

Item Number	Description	Change Frequency*
W3T324512	Tank 30 l	
W3T324513	Tank 60 l without pump	
W3T234643	Tank 60 l with pump	
W3T324515	Tank 80 l with pump 8 l/min	
W3T324514	Tank 80 l with pump 1.2 l/min	
W3T339714	CO ₂ + UV Kit for 30 l	12 months
W3T339715	CO ₂ + UV Kit for 60 l	12 months
W3T324529	UV Kit 30, 60 l tank	12 months
W3T339692	UV Lamp 80 l tank	12 months
W3T314413	Degassing unit	