



Ionpure® VNX Enhanced Performance High Flow Continuous Electrodeionization (CEDI) Modules

IONPURE® VNX-EP RANGE OF HIGH FLOW CONTINUOUS ELECTRODEIONIZATION (CEDI) MODULES

IONPURE VNX ENHANCED PERFORMANCE MODULES

The Ionpure® VNX-EP high flow module is designed with proven continuous electrodeionization (CEDI) technology to produce high purity water. Proprietary Flexmount™ connectors create a support system for the modules, which simplifies the systems design to reduce overall capital cost.

The VNX-EP range provides ultrapure water for critical boilers in the power industry and other bulk deionization high purity applications. Multiple VNX-EP modules provide for simplified system design with flow rates up to, and greater than 1,000 gpm.

VNX55-EP Series Features

- Typically > 17 MΩ-cm product water resistivity
- Designed to meet low sodium, chloride, and sulfate requirements for super critical boilers
- Silica and Boron removal is typically > 95%
- 1 ppm maximum feed water hardness (as CaCO₃)
- Up to 95% recovery
- No need for acid/caustic, neutralization systems or DI tank exchanges
- Robust leak free sealing with through-port gasket
- Connection fittings are included
- On-board junction box
- Available as 55 gpm (12.5 m³/h) or 27.5 (6.2 m³/h) nominal flow rates

For additional information on our VNX Series call +1 866.876.3340 or visit our website at www.ionpure.com.

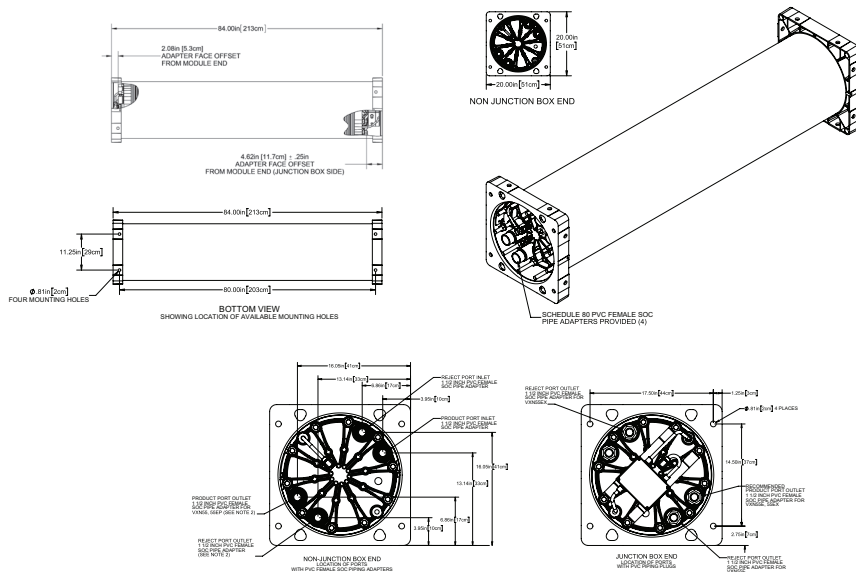

*VNX55-EP Module shown

OPERATING ENVIRONMENT

Installation should be indoors with no direct sunlight and should have a maximum ambient room temperature of 113°F (45°C).

MATERIAL CONSTRUCTION

- Wetted components of the VNX module consist of: PVC (adapters), nylon/ABS, polypropylene, silicone, ion-selective membranes, ion exchange resins and thermoplastic elastomer.
- Housing is fiberglass reinforced plastic (FRP). Standard color is white with a glossy finish. Custom colors and labeling are available.
- The proprietary Flexmount™ bracket/end-block assembly is an epoxy painted aluminum casting suitable for securing modules to the frames and/or each other in Ionpure® system approved configurations.

QUALITY ASSURANCE STANDARDS

CE marked. Each module is factory tested to meet strict industry standards and is manufactured in an ISO 9001 and ISO 14000 quality and environmental management system.

Halal Certification. All Ionpure modules are manufactured in accordance with the Islamic Food and Nutrition Council of America standards (IFANCA), and will carry the Crescent M Halal logo.

ORDERING INFORMATION

Item No.	Model No.	Description
W3T262280	IP-VNX55EP-2	VNX55-EP
W3T339521	IP-VNX28EP-2	VNX28-EP

- Each VNX module has four process connections; feed, concentrate feed, product and reject. PVC adapters (with dust covers) and plugs are provided with the module. High purity 50 mm polypropylene adapters are also available.
- Module electrical power connections are made through an on-board junction box.

Physical Specifications

Product	Width	Height	Length	Shipping Weight	Operating Weight
VNX55-EP	20" (50.8 cm)	20" (50.8 cm)	84" (213.3 cm)	610 lbs (276.7 kg)	825 lbs (374.2 kg)
VNX28-EP	20" (50.8 cm)	20" (50.8 cm)	44" (111.8 cm)	315 lbs (143 kg)	420 lbs (190.5 kg)

Maximum Feed Water Specifications

Feed Water Conductivity Equivalent, including CO ₂ and Silica	<40µS/cm
Feed Water Source	RO permeate or DI water
Temperature	41 - 113°F (5 - 45°C)
Inlet Pressure	20 - 100psi (1.4 - 7bar)
Maximum Total Chlorine (as Cl ₂)	< 0.02 ppm
Iron (as Fe)	< 0.01 ppm
Manganese (as Mn)	< 0.01 ppm
Sulfide (S ²⁻)	< 0.01 ppm
pH	4 - 11
Total Hardness (as CaCO ₃)	≤ 1.0 ppm
Dissolved Organics (TOC as C)	< 0.5 ppm
Silica (SiO ₂)	< 1.0 ppm

Typical Module Performance

Operating Parameters		
	VNX28-EP	VNX55-EP
Recovery	90 - 95%	
Minimum Flow	12.5 gpm (2.8m ³ /h)	25.0 gpm (5.7m ³ /H)
Nominal Flow	27.5 gpm (6.2 m ³ /h)	55.0 gpm (12.5 m ³ /h)
Maximum Flow	41.25 gpm (9.4 m ³ /h)	82.5 gpm (18.7 m ³ /h)
DC Voltage	0 - 300	
DC Amperage	1 - 6.6	1 - 13.2

Product Water Quality

Product Resistivity - RO Permeate	> 17 MΩ.cm*
Product Resistivity - DI Water	> 18 MΩ.cm*
Silica (SiO ₂) Removal	≥ 95%
Boron (B) Removal	≥ 95%
Sodium (Na ⁺) Removal	99.8%
Chloride (Cl ⁻) Removal	99.8%

*Actual performance may be determined using the IP-Pro projection software available from Ionpure.